

MGM Brakes

A Division of Indian Head Industries, Inc.

TECHNICAL BULLETIN

SUBJECT: EB 13-006 - Air Disc Brake Actuator Service Manual

MGM Brakes service and spring brake actuators are important parts of your air disc braking system. These actuators contain no serviceable parts and are not to be dis-assembled. The following instructions cover the inspection, removal and installation of service and spring brake actuators on air disc brakes.

⚠ WARNING – Before performing any work on the vehicle’s air brake system, or any pressurized component, understand and follow the vehicle manufacturer’s recommendations for placing the vehicle in a safe working condition.

Always block wheels to prevent vehicle rollaway when performing any brake maintenance.

Do not attempt to remove or install any brake actuator until you understand the recommended procedure. Use only the proper tools and observe all precautions pertaining to the use of those tools.

Replace any damaged or failed brake actuator with an approved replacement brake actuator of the same size, and type as originally installed on the vehicle.

IMPORTANT – Disc brake actuators can only be installed on a vehicle if the boot seal protrudes a minimum of 3mm (0.118 in) from the mounting surface (Fig. 1). Any actuator that is removed must be inspected for cracks, damage or tears to the boot seal, and the boot seal height measured. The internal boot that seals the caliper from contaminants may have taken a set and may not seal correctly upon re-installation if found to be damaged, torn, or cracked, or with seal protrusion less than 3mm (0.118 in). Ensure caliper and brake actuator mounting surfaces are clean, dry and free of corrosion prior to installation.

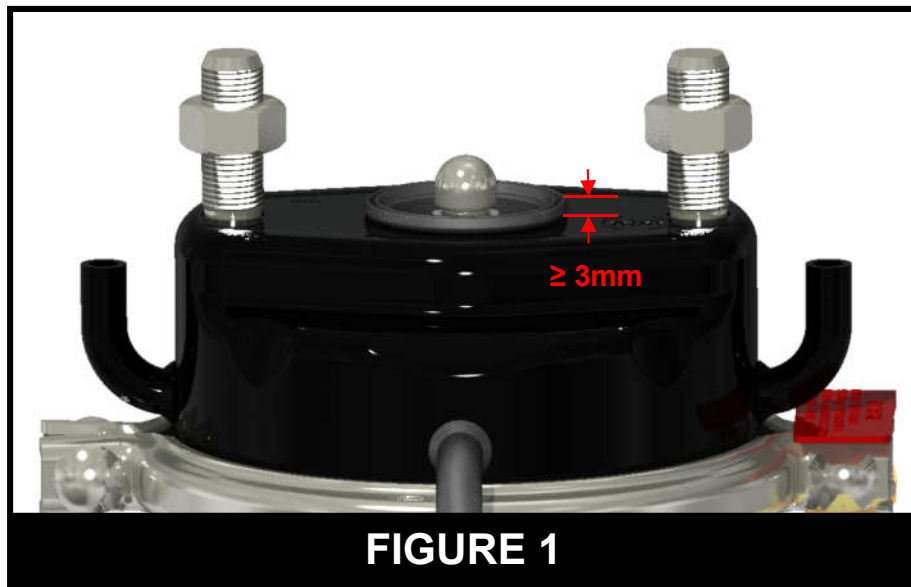

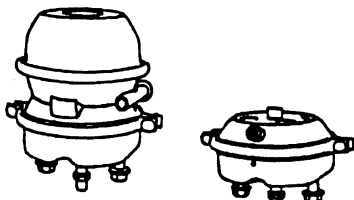

MGM Brakes

A Division of Indian Head Industries, Inc.

TECHNICAL BULLETIN

SUBJECT: EB 13-006 - Air Disc Brake Actuator Service Manual

SECTION 1: SERVICE BRAKE ACTUATORS (See Section 2 or 3 for Spring Brake Actuators)

1.1 Recommended Inspection Points (Fig. 2)

(1.1a) Visually inspect the exterior surfaces of the actuator for signs of damage. If any is seen or suspected, carefully remove and replace the actuator by following the directions in this manual.

(1.1b) Using vehicle system air, apply full system pressure of 100 psi (690 kPa) minimum to service the brake actuator. Test for air leaks around circumference of clamp band and air inlet fittings with soapy water or leak detection solution.

- Clamp band – If bubbles appear around clamp band, release air pressure from service chamber and tighten clamp band nuts to 30-35 ft-lbs (41-47 Nm) torque using 9/16-inch wrench. Recheck for leaks. If leaks continue, follow the procedure in Section 5.2.
- Air inlet fittings - Tighten fittings until leaks cease. Remove air pressure when tightening fittings. Do not over-torque: 25-30 ft-lbs (34-40 Nm) for 3/8-18 NPTF fittings, 13-15 ft-lbs (18-20 Nm) for M16x1.5-6H fittings, 27-33 ft-lbs (37-44 Nm) for M22x1.5-6H fittings. If leaks continue, follow the procedure in Section 5.2. Repair or replace hoses and fittings as required.

(1.1c) Check to ensure the mounting stud nuts are tightened to 133-155 ft-lbs (180-210 Nm) torque (clockwise) using a 24 mm wrench.

1.2 Removal Instructions

(1.2a) With all air pressure drained from actuator, remove air line from the air-inlet port.

(1.2b) Remove and discard mounting stud nuts and carefully remove the old actuator from the caliper.

1.3 Installation Instructions

IMPORTANT - It is important to replace the removed brake actuator with an approved replacement service brake actuator of the same size, and type as originally installed on the vehicle.

(1.3a) Before installing the brake actuator, ensure the caliper mounting surface is clean, dry and free of corrosion. Take necessary precautions to keep dirt and debris out of the caliper while cleaning. Grease the lever arm and any other points in accordance with the caliper manufacturer's recommendations.

(1.3b) Remove mounting hardware on mounting studs of new actuator. Install actuator on caliper with close attention given to positioning chamber air-inlet ports for alignment to vehicle air lines.

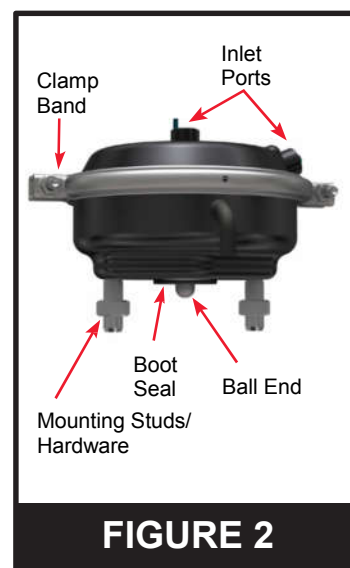
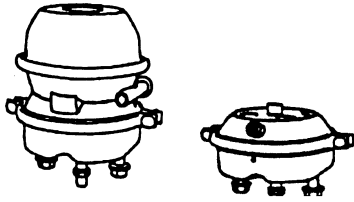

FIGURE 2



MGM Brakes

A Division of Indian Head Industries, Inc.

TECHNICAL BULLETIN

SUBJECT: EB 13-006 - Air Disc Brake Actuator Service Manual

IMPORTANT – All air disc service actuators contain an internal boot to seal the caliper from contaminants (Fig. 1). Do not attempt to rotate or reposition ports by loosening clamp band bolts and nuts nor use any clamping tools such as vice grips to hold the push rod as damage to the boot may occur.

Install mounting hardware on mounting studs and, using a 24 mm hand wrench alternately tighten the nuts to MGM Brakes recommended 133-155 ft-lbs (180-210 Nm) torque.

- (1.3c) Install air line to the chamber making sure it is mated to the correct air-inlet port. MGM Brakes recommends 3/8-18 NPTF fittings be tightened to 25-30 ft-lbs (34-40Nm) torque, M16x1.5-6H tightened to 13-15 ft-lbs (18-20 Nm) torque, and M22x1.5-6H tightened to 27-33 ft-lbs (37-44 Nm) torque into the chamber's air-inlet ports.
- (1.3d) Using vehicle system air, apply full system pressure of 100 psi (690 kPa) minimum to test for air leaks at air inlet fittings with soapy water or leak detection solution. Refer to Section 1.1b for leak check procedures.
- (1.3e) Exhaust air pressure from service chamber.

SECTION 2: PISTON STYLE SPRING BRAKE ACTUATORS (MGM Brakes Tamper-Resistant MAGNUM Performance Plus Spring Brake Actuators)

2.1 Recommended Inspection Points (Fig. 3, on page 4 – top)

- (2.1a) Visually inspect the exterior surfaces of the spring brake actuator for signs of damage. If any is seen or suspected, carefully remove and replace the actuator by following the directions in this manual.
- (2.1b) Using vehicle system air, apply full system pressure of 100 psi (690 kPa) minimum to the spring brake chamber. Using soapy water or leak detection solution, inspect for air leaks at the head/flange case interface, air inlet fittings, at vent elbows in non-pressure housing, and center seal.
 - Head / flange case interface – If a leak is detected, follow the procedure in Section 5.1.
 - Air inlet fittings - Tighten fittings until leaks cease. Remove air pressure when tightening fittings. Do not over-torque: 25-30 ft-lbs (34-40 Nm) for 3/8-18 NPTF fittings, 13-15 ft-lbs (18-20 Nm) for M16x1.5-6H fittings, 27-33 ft-lbs (37-44 Nm) for M22x1.5-6H fittings. If leaks continue, follow the procedure in Section 5.1. Repair or replace hoses and fittings as required.
 - Non-pressure housing vent elbow - If more than one vent elbow is present, plug all but one elbow and check for leaks at the unplugged elbow. If a leak is detected, there is an internal leak, and follow the procedure in Section 5.1.
 - Center seal leak – check for continuous discharge from the service side quick release valve. If a leak is detected, follow the procedure in Section 5.1.

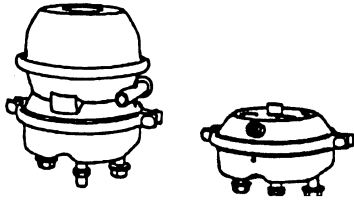

MGM Brakes

A Division of Indian Head Industries, Inc.

TECHNICAL BULLETIN

SUBJECT: EB 13-006 - Air Disc Brake Actuator Service Manual

(2.1c) With spring brake still fully pressurized, apply full system pressure of 100 psi (690kPa) minimum to the service brake chamber. Test for air leaks around circumference of clamp band, and air inlet fittings with soapy water or leak detection solution.

- Clamp band – If bubbles appear around clamp band, release air pressure from service chamber and tighten clamp band nuts to 30-35 ft-lbs (41-47 Nm) torque using 9/16-inch wrench. Recheck for leaks. If leaks continue, follow the procedure in Section 5.2.
- Air inlet fittings - Tighten fittings until leaks cease. Remove air pressure when tightening fittings. Do not over-torque: 25-30 ft-lbs (34-40 Nm) for 3/8-18 NPTF fittings, 13-15 ft-lbs (18-20 Nm) for M16x1.5-6H fittings, 27-33 ft-lbs (37-44 Nm) for M22x1.5-6H fittings. If leaks continue, follow the procedure in Section 5.2. Repair or replace hoses and fittings as required.

(2.1d) Check to ensure the mounting stud nuts are tightened to 133-155 ft-lbs (180-210 Nm) torque (clockwise) using a 24 mm wrench.

(2.1e) Check to ensure that the RELEASE BOLT is seated against head insert and tightened to 50-60 ft-lbs (68-81 Nm) torque using a 3/4-inch wrench

! WARNING – DO NOT USE AN IMPACT WRENCH.

This ensures the parking brake will have full stroke capability and seals the release bolt threads, keeping out contaminants.

(2.1f) Check the external breather tube to ensure there is no damage or cracks in the rubber elbows and ensure the tube is securely engaged a minimum of 1/2-inch (13 mm) into the rubber elbows and glued together with a high quality rubber cement, or secured with hose clamps. Replace with MGM Brakes Breather Tube Kit part number 9081001 if necessary.

2.2 Removal Instructions

(2.2a) Manually cage the spring by turning the integral release bolt counter-clockwise using a 3/4-inch socket wrench (Fig. 4) until the spring is fully caged.

! WARNING – DO NOT USE AN IMPACT WRENCH.

NOTE - For easier turning of the release bolt, apply 95-125 psi (655-862 kPa) of air pressure to the air-inlet port marked “Spring”. After caging, completely exhaust air from the spring chamber.

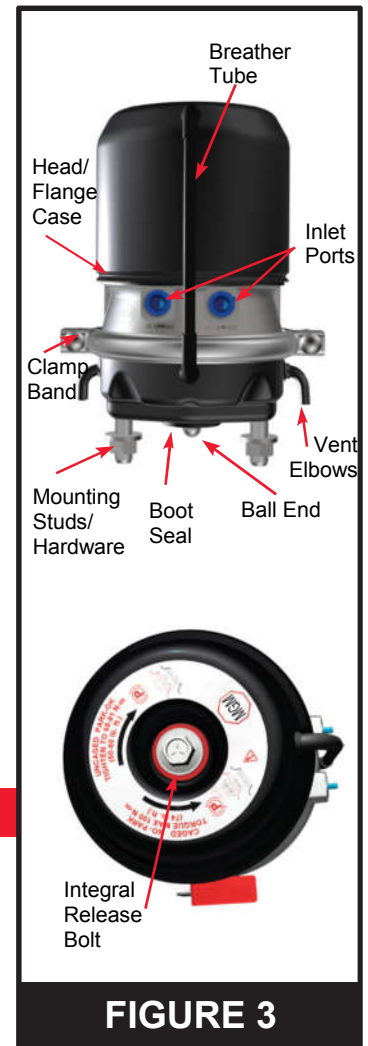
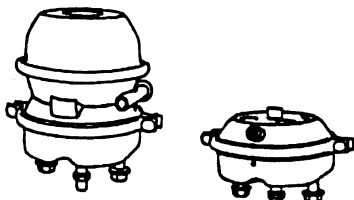

FIGURE 3



MGM Brakes

A Division of Indian Head Industries, Inc.

TECHNICAL BULLETIN

SUBJECT: EB 13-006 - Air Disc Brake Actuator Service Manual

MAGNUM Performance Plus models have an MGM Brakes patented dual thread release bolt which reduces the travel of the release bolt by a factor of 2.4. For a 2.50-inch (63.5 mm) stroke unit, the parking spring is fully caged when the release bolt extends approximately 1.1 inches (28 mm) from the run position, or 18 to 19 turns. For a 3.00-inch (76 mm) stroke unit, the parking spring is fully caged when the release bolt extends approximately 1.3 inches (33 mm) from the run position, or 22 to 23 turns (Fig. 5).

⚠ WARNING - Do not exceed this length and do not exceed 74 ft-lbs (100 Nm) torque on the release bolt at any time or damage may occur which could affect the performance of the spring brake chamber. If this occurs, replacement of the actuator is required.

- (2.2b) With all air pressure drained from the service and spring chambers of the actuator, mark and remove the air lines from the air-inlet ports.
- (2.2c) Remove and discard mounting stud nuts and carefully remove the old chamber from the caliper.
- (2.2d) See Section 4 for disposal instructions.

2.3 Installation Instructions

IMPORTANT - It is important to replace the removed spring brake actuator with approved replacement spring brake actuators of the same size, and type as originally installed on the vehicle. When replacing any other model air brake actuator with a MAGNUM Performance Plus (MJ-Series) model actuator it is recommended that both actuators on the same axle be replaced to ensure braking stability. The parking brake forces are significantly different and using two different actuators on the same axle could cause brake pull during an emergency brake application.

- (2.3a) Before installing the brake actuator, ensure the caliper mounting surface is clean, dry, and free of corrosion. Take necessary precautions to keep dirt and debris out of the caliper while cleaning. Grease the lever arm and any other points in accordance with the caliper manufacturer's recommendations.
- (2.3b) Remove the mounting hardware on mounting bolts of new actuator. Place actuator on caliper with close attention given to positioning actuator air-inlet ports for alignment to vehicle air lines.

IMPORTANT – All disc spring brake actuators contain an internal boot to seal the caliper from contaminants. Do not attempt to rotate or reposition ports by loosening clamp band bolts and nuts nor use any clamping tools such as vice grips to hold the push rod as damage to the boot may occur.



FIGURE 4



FIGURE 5

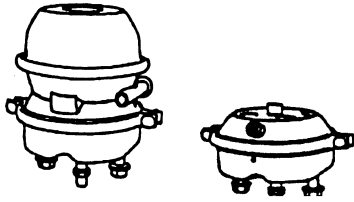

MGM Brakes

A Division of Indian Head Industries, Inc.

TECHNICAL BULLETIN

SUBJECT: EB 13-006 - Air Disc Brake Actuator Service Manual

IMPORTANT – When installing any MGM Brakes MAGNUM Performance Plus model actuator it is mandatory to position the actuator so the breather tube faces away from the road surface (Fig. 6). Failure to comply will void the MGM Brakes Warranty on these models.

Install mounting hardware on mounting bolts and, using a 24 mm hand wrench alternately tighten the nuts to MGM Brakes recommended 133-155 ft-lbs (180-210 Nm) torque.

- (2.3c) Install both air lines to the actuator making sure each is mated to the correct air-inlet port according to markings made earlier. MGM Brakes recommends 3/8-18 NPTF fittings be tightened to 25-30 ft-lbs (34-40Nm) torque, M16x1.5-6H tightened to 13-15 ft-lbs (18-20 Nm) torque, and M22x1.5-6H tightened to 27-33 ft-lbs (37-44 Nm) torque into the chamber's air-inlet ports.
- (2.3d) Using vehicle system air, apply the spring brake chamber full system pressure of 100 psi (690 kPa) minimum. Using soapy water or leak detection solution, inspect for air leaks at air inlet fittings. Refer to Section 2.1b for leak check procedures.
- (2.3e) With spring brake still fully pressurized, apply full system pressure of 100 psi (690 kPa) minimum to service brake chamber. Test for air leaks at air inlet fittings with soapy water or leak detection solution. Refer to Section 2.1c for leak check procedures.
- (2.3f) Exhaust air pressure from service brake chamber and with air pressure still applied to spring brake chamber, tighten the release bolt clockwise until it is seated against the head insert and torqued to 50-60 ft-lbs (68-81 Nm). This will ensure the parking brake will have full stroke capability and the release bolt threads will seal out contaminants.
- (2.3g) Exhaust air pressure from spring brake.

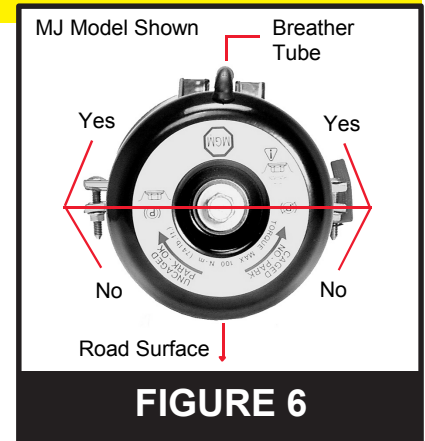
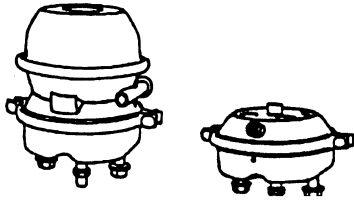

FIGURE 6

SECTION 3: TR-T DOUBLE DIAPHRAGM SPRING BRAKES

3.1 Recommended Inspection Points (Fig. 7, on page 7 - top)

- (3.1a) Visually inspect the exterior surfaces of the spring brake actuator for signs of damage. If any is seen or suspected, carefully remove and replace the actuator by following the directions in this manual.
- (3.1b) Using vehicle system air, apply full system pressure of 100 psi (690 kPa) minimum to the spring brake chamber. Using soapy water or leak detection solution, inspect for air leaks at the head/flange case interface, air inlet fittings, at vent elbows in non-pressure housing, and center seal.
- Head / flange case interface – If a leak is detected, follow the procedure in Section 5.1.
 - Non-pressure housing vent elbow - If more than one vent elbow is present, plug all but one elbow and check for leaks at the unplugged elbow. If a leak is detected, there is an internal leak, and follow the procedure in Section 5.1.



MGM Brakes

A Division of Indian Head Industries, Inc.

TECHNICAL BULLETIN

SUBJECT: EB 13-006 - Air Disc Brake Actuator Service Manual

- Center seal leak – check for continuous discharge from the service side quick release valve. If a leak is detected, follow the procedure in Section 5.1.
- (3.1c) With spring brake still fully pressurized, apply full system pressure of 100 psi (690kPa) minimum to the service brake chamber. Test for air leaks around circumference of clamp band, and air inlet fittings with soapy water or leak detection solution.
- Clamp band – If bubbles appear around clamp band, release air pressure from service chamber and tighten clamp band nuts to 30-35 ft-lbs (41-47 Nm) torque using 9/16-inch wrench. Recheck for leaks. If leaks continue, follow the procedure in Section 5.2.
 - Air inlet fittings - Tighten fittings until leaks cease. Remove air pressure when tightening fittings. Do not over-torque: 25-30 ft-lbs (34-40 Nm) for 3/8-18 NPTF fittings, 13-15 ft-lbs (18-20 Nm) for M16x1.5-6H fittings, 27-33 ft-lbs (37-44 Nm) for M22x1.5-6H fittings. If leaks continue, follow the procedure in Section 5.2. Repair or replace hoses and fittings as required
- (3.1d) Check to ensure the mounting stud nuts are tightened to 133-155 ft-lbs (180-210 Nm) torque (clockwise) using a 24 mm wrench.
- (3.1e) Ensure the Weatherseal end cap is snapped tight into place and equipped with a rubber O-ring to ensure proper sealing of the spring chamber. Replace as necessary with kit part number 9019005 (9019006 for TR3036 models).
- (3.1f) Check to ensure the release-bolt, flat washer and release-nut are properly secured in the storage pocket. MGM Brakes recommends 10 ft-lbs (14 Nm) torque on nut against the flat washer.
- (3.1g) Check the external breather tube to ensure there is no damage or cracks in the rubber elbows and ensure the tube is securely engaged a minimum of 1/2-inch (13 mm) into the rubber elbows and glued together with a high quality rubber cement, or secured with hose clamps. Replace with MGM Brakes Breather Tube Kit part number 9081001 if necessary.

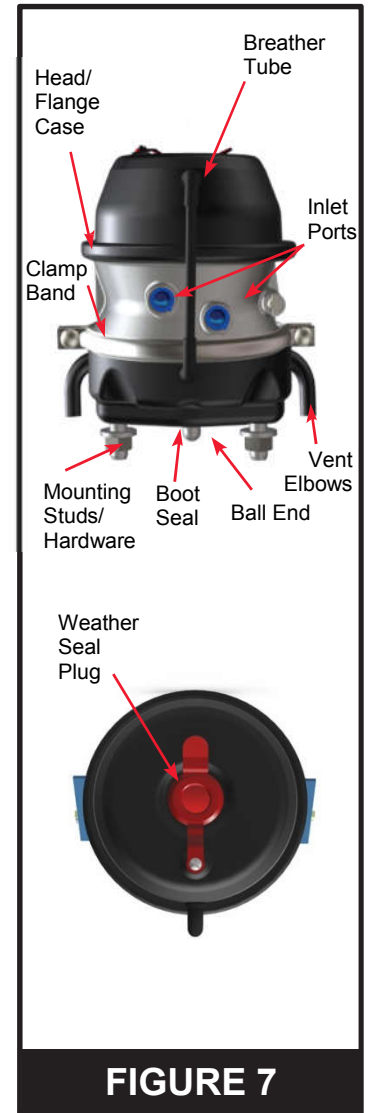

3.2 Removal Instructions

- (3.2a) Remove the Weatherseal end cap from the spring brake chamber.
- (3.2b) Using a 3/4-inch (15/16-inch for TR3036 models) wrench, unscrew the release-nut and remove the nut, flat washer, and release-bolt from their storage pocket on the side of the actuator (Fig. 8). If these parts are not stored on the actuator, they must be obtained from the vehicle's tool box or service department, as the spring brake cannot be manually released without them.

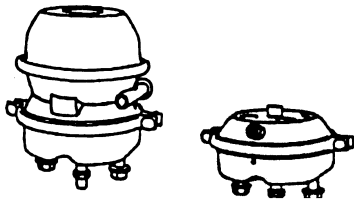

MGM Brakes

A Division of Indian Head Industries, Inc.

TECHNICAL BULLETIN

SUBJECT: EB 13-006 - Air Disc Brake Actuator Service Manual

IMPORTANT – Use of MGM Brakes release bolt is required for proper fit and operation.

NOTE – For easier turning of the release bolt, apply 95-125 psi (655-862 kPa) of air pressure to the air-inlet port marked “Spring” before Step (3.2b) above. After caging, completely exhaust air from the spring chamber.

Insert the “T” end of the release-bolt into the centerhole of the head and, being sure that the formed end of the bolt has entered the hole in the piston inside the chamber, continue to insert the bolt until it bottoms out (Fig. 9). Turn the release-bolt 1/4 turn clockwise and pull the bolt out to lock the formed end into the piston.

Holding the bolt locked into the piston, install the flat washer and the release-nut on the end of the release-bolt, and turn down the nut against the flat washer until finger tight (Fig. 10).

Figure 8

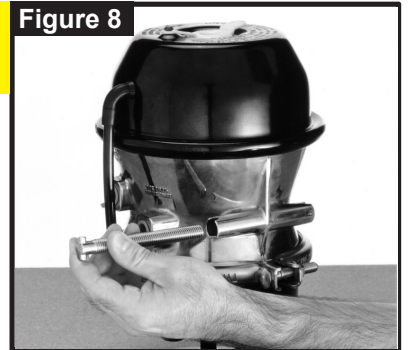

Figure 9



Figure 10



Figure 11

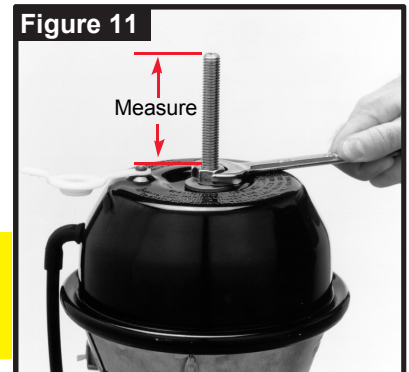

WARNING – DO NOT USE AN IMPACT WRENCH

Using a 3/4-inch (15/16-inch for TR3036 models) hand wrench turn the release-nut clockwise until the following length of bolt extends above the nut (Fig. 11).

3.25 inch (82.6 mm) – Type xx24 and Type xx30 Actuator
4.00 inch (101.6 mm) – Type xx36 Actuator



WARNING – Do not exceed these lengths and do not exceed 50 ft-lbs (68 Nm) torque on release-nut at any time or damage may occur, which could prevent any future correct manual-releasing of the spring brake chamber.

(3.2c) With all air pressure drained from the service and spring chambers of the actuator, mark and remove the air lines from the air-inlet ports.

(3.2d) Remove and discard mounting stud nuts and carefully remove the old actuator from the caliper.

(3.2e) See section 4 for disposal instructions.

3.3 Installation Instructions

IMPORTANT – It is important to replace the spring brake actuator with approved replacement brake actuators of the same size, and type as originally installed on the vehicle.

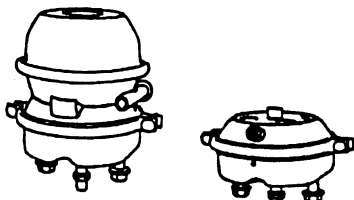

MGM Brakes

A Division of Indian Head Industries, Inc.

TECHNICAL BULLETIN

SUBJECT: EB 13-006 - Air Disc Brake Actuator Service Manual

- (3.3a) Before installing the brake actuator, ensure the caliper mounting surface is clean, dry and free of corrosion. Take necessary precautions to keep dirt and debris out of the caliper while cleaning. Grease the lever arm and any other points in accordance with the caliper manufacturer's recommendations.
- (3.3b) Remove mounting hardware on mounting bolts of new actuator. Place actuator on caliper with close attention given to positioning actuator air-inlet ports for alignment to vehicle air lines.

IMPORTANT – All disc spring brake actuators contain an internal boot to seal the caliper from contaminants. Do not attempt to rotate or reposition ports by loosening clamp band bolts and nuts nor use any clamping tools such as vice grips to hold the push rod as damage to the boot may occur.

IMPORTANT – When installing any MGM Brakes TR-T model actuator it is mandatory to position the actuator so the breather tube faces away from the road surface (Fig. 6). Failure to comply will void the MGM Brakes Warranty on these models.

Install mounting hardware on mounting bolts and, using a 24 mm hand wrench alternately tighten the nuts to MGM Brakes recommended 133-155 ft-lbs (180-210 Nm) torque.

- (3.3c) Install both air lines to the chamber making sure each is mated to the correct air-inlet port according to markings made earlier. MGM Brakes recommends 3/8-18 NPTF fittings be tightened to 25-30 ft-lbs (34-40Nm) torque, M16x1.5-6H tightened to 13-15 ft-lbs (18-20 Nm) torque, and M22x1.5-6H tightened to 27-33 ft-lbs (37-44 Nm) torque into the chamber's air-inlet ports.
- (3.3d) Using vehicle system air, apply to spring brake full line air pressure of (100 psi/690 kPa) minimum. Using only soapy water or leak detection solution, inspect for air leaks at air lines and fittings. Refer to Section 3.1b for leak check procedures.
- (3.3e) With spring brake still fully pressurized, apply full line air pressure of (100 psi/690 kPa) minimum to service brake chamber. Test for air leaks at air lines and fittings with soapy water or leak detection solution. Refer to Section 3.1c for leak check procedures.
- (3.3f) Exhaust air pressure from the service chamber and with air pressure still applied on the spring brake, remove release-nut, washer and release-bolt for all "TR" models. Replace these parts in their storage pocket (Fig. 12) on chamber (or in vehicle tool box if storage pocket is not present on chamber) and tighten nut against flat washer to 10 ft-lbs (14 Nm) torque.
- (3.3g) Properly replace the Weatherseal end cap.

IMPORTANT – Operating units equipped with the EXTERNAL BREATHING TUBE without the Weatherseal end cap and O-RING securely in place will void the MGM Brakes Warranty without remedy.



- (3.3h) Exhaust air pressure from spring brake.

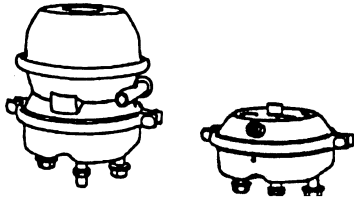

MGM Brakes

A Division of Indian Head Industries, Inc.

TECHNICAL BULLETIN

SUBJECT: EB 13-006 - Air Disc Brake Actuator Service Manual

SECTION 4: RECOMMENDED SPRING BRAKE ACTUATOR DISARMING PROCEDURE

All retired spring brake actuators should be safely disarmed before they are disposed of to prevent serious personal injury from accidental sudden release of the high energy power spring (as much as 3200 lbs./1450 kgs) in the spring (or parking) chamber. To disarm the unit, remove it from the vehicle following the instructions in this manual. Be sure to cage the spring.

⚠ WARNING - NEVER attempt to remove the head which contains the power spring. Observe all safety precautions. Place the unit in an approved steel container and use an acetylene torch to cut a hole through the head housing the power spring. Cut completely through at least two spring coils. The steel container **MUST have openings to expose the head where it is to be cut with the acetylene torch, and it **MUST** be strong enough to prevent parts from hurtling out should the unit suddenly separate before it is safely disarmed. It is the user's responsibility to ensure the steel container is safe.***

***Information concerning a suitable container is available from your MGM Brakes representative.**

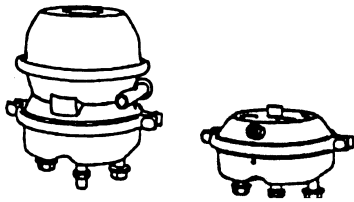

MGM Brakes

A Division of Indian Head Industries, Inc.

TECHNICAL BULLETIN

SUBJECT: EB 13-006 - Air Disc Brake Actuator Service Manual

SECTION 5: Air Leak Test Procedure and Allowable Pressure Loss

5.1 Leak Testing Procedure – Parking Spring Air Supply Port 12, Piston/Diaphragm and Double Diaphragm Models

(5.1a) Connect the leak test system to parking spring supply port 12 per Figure 13 (Piston/Diaphragm brake actuator shown, same set up for Double diaphragm brake actuator).

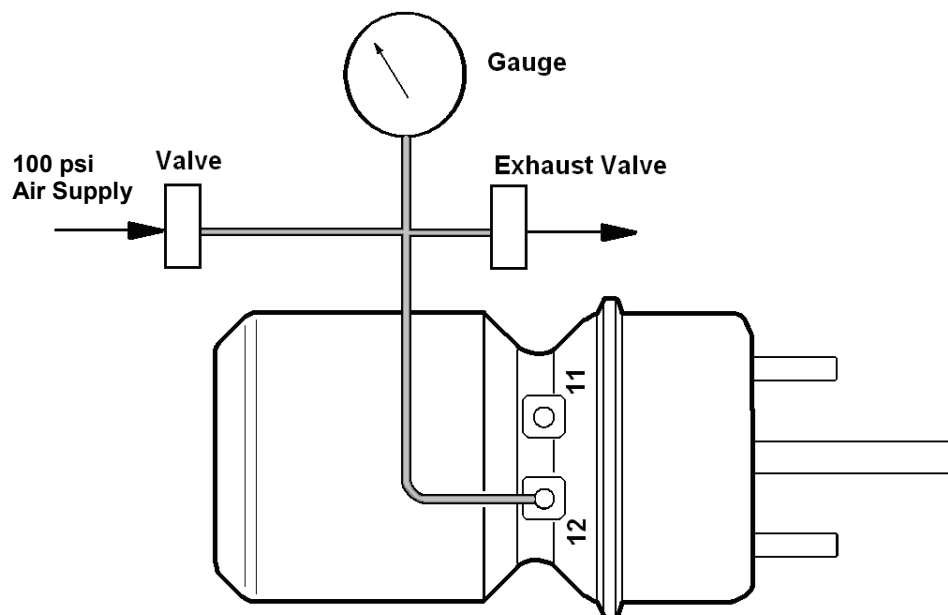
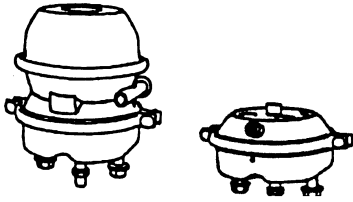

Figure 13

- (5.1b) Close exhaust valve.
- (5.1c) Open the air supply valve. Pressurize the parking chamber to 100 psi. Note: Some minor movement (2.5 mm Max) to initially position the head may be noticed at the roll in area of a Piston/Diaphragm brake actuator, this is normal and should give no concern. (Ref. Bulletin EB 06-005)
- (5.1d) Uncage spring brake. Reference Section 2 for Piston/Diaphragm brake actuator. Reference Section 3 for Double Diaphragm brake actuator.
- (5.1e) Cycle unit 2 to 3 times by releasing and applying air pressure. Caution – be careful of rod movement.
- (5.1f) Pressurize the system to 100 psi and close the air supply valve.
- (5.1g) Wait for the system to stabilize; approximately 1 minute.
- (5.1h) Open the air supply valve to restore the test system to 100 psi.
- (5.1i) Close the air supply valve and begin counting the time (3 minutes).



TECHNICAL BULLETIN

SUBJECT: EB 13-006 - Air Disc Brake Actuator Service Manual

- (5.1j) After 3 minutes, record the final pressure and compare against the following chart. If the final pressure does not meet the minimum allowable pressure as listed in the table below, carefully remove and replace the actuator by following the directions in this manual.

Model Series	Spring Chamber Size (Type)	Rated Stroke (in)	Minimum Allowable Pressure (Gauge) after 3 minutes (psi)
J	24	2.5	95
J	24	3.0	95
J	28	3.0	97
J	30	3.0	97
TR	24	2.5	95
TR	30	2.5	96
TR	36	2.5	97

5.2 Leak Testing Procedure – Service Air Supply Port 11, Piston/Diaphragm, Double Diaphragm, and Service Brake Actuators

- (5.2a) Connect the leak test system to spring supply port 12 and service supply port 11 per Figure 14. For Service brake actuators, disregard spring chamber set up and procedures. Service leak check procedure remains the same for these actuators.

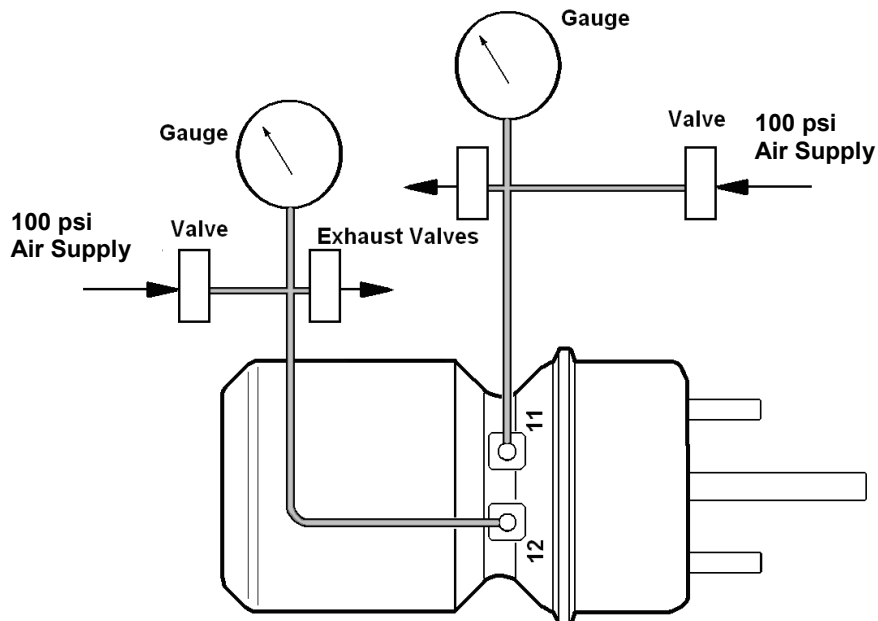
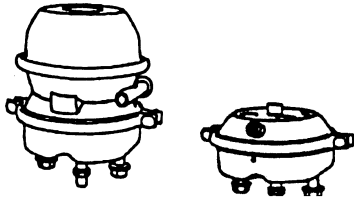

Figure 14



MGM Brakes

A Division of Indian Head Industries, Inc.

TECHNICAL BULLETIN

SUBJECT: EB 13-006 - Air Disc Brake Actuator Service Manual

- (5.2b) Close exhaust valves
- (5.2c) Open the air supply valve to port 12
- (5.2d) Pressurize port 12 to 100 psi (Spring caged)
- (5.2e) Open the air supply valve to port 11
- (5.2f) Pressurize the service side (port 11) to 100 psi
- (5.2 g) Cycle unit 2 to 3 times by releasing and applying air pressure from and to the service side. Leave the spring side pressurized. Caution – be careful of rod movement
- (5.2h) Pressurize the service side (port 11) to 100 psi and close the air supply valve.
- (5.2i) Wait for the system to stabilize; approximately 1 minute
- (5.2j) Open the air supply valve (port 11) to restore the test system to 100 psi
- (5.2k) Close the air supply valve and begin counting the time (3 minutes)
- (5.2l) After 3 minutes, record the final pressure and compare against the following chart. If the final pressure does not meet the minimum allowable pressure as listed in the table below, carefully remove and replace the actuator by following the directions in this manual.

Model Series	Service Chamber Size (Type)	Rated Stroke (in)	Minimum Allowable Pressure (Gauge) after 3 minutes (psi)
Service Brake Actuator	16	2.5	91
	18	2.5	91
	20	2.5	90
	22	2.5	91
	24	2.5	91
	30	2.5	93
Piston/Diaphragm Brake Actuator	16	2.5	90
	18	2.5	90
	20	2.5	90
	22	2.5	91
	24	2.5	91
	20	3.0	91
	24	3.0	93
	30	3.0	94
Double Diaphragm Brake Actuator	16	2.5	90
	18	2.5	90
	20	2.5	90
	22	2.5	91
	24	2.5	91
	30	2.5	93