



MGM Brakes

DIFFERENT PRODUCTS FOR SEVERE ENVIRONMENTS



Heavy Duty Transport & Tankers

Mobile Cranes

Livestock Transport

City Bus & Coach

Military Vehicles



Off Road & Severe Service Vehicles

Waste & Recycling Trucks

Emergency Vehicles

RUGGED BRAKES FOR TOUGH JOBS



DESIGNED FOR SEVERE OPERATING ENVIRONMENTS

MGM Brakes • A Division of Indian Head Industries, Inc.
www.mgmbrakes.com • e-mail: mail@mgmbrakes.com

VARIOUS MODELS FOR YOUR RUGGED, HEAVY DUTY NEEDS

Fully Epoxy Coated Models

- “Optional” stainless steel clevis pin
- Center hole stone shield prevents entry of contaminants
- Available hybrid diaphragm for better resistance to oil/contaminants
- Corrosion Fighter technology for complete corrosion protection
- Fully epoxy coated inside and out for extreme corrosion protection
- Welded reinforced mounting studs available
- Heavy-duty reinforced diaphragms



Heavy-duty Diaphragms

Piston Brake Models

- High performance synthetic polymer center seal
- Increased parking spring force output
- High force parking spring brakes available
- Patented dual thread release bolt provides minimum bolt protrusion
- Optional urethane diaphragm for better ozone resistance
- Compact design due to smaller diameter, shorter height

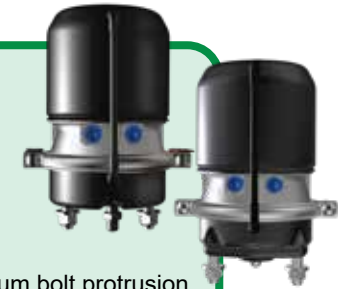

Rubber Center Seal

1.	Release Bolt	Patented “Dual Thread Bolt” design which provides minimal bolt protrusion at maximum release.
2.	“Long Life” Power Spring	Powerful, reliable, non-coil clash design. Heat-fused epoxy-coated for maximum corrosion protection.
3.	Piston Seal and Guide Ring	Main seal is molded from high performance synthetic polymer to provide long term protection against air leaks. Guide ring is “self-lubricating” for long service life.
4.	Steel Head	MGM Brakes “Roll-in” tamper resistant steel head design provides high-impact protection and has a tough, abrasion resistance coating to battle corrosion.
5.	External Breather Tube	Vents air from the inside protected area of the non-pressure chamber to effectively seal out liquid and solid corrosive airborne contaminants.
6.	Center Case Push-Rod and Seal	Aluminum push-rod surface is hard coat finished and slightly porous to retain lubricants
7.	Heavy-Duty Diaphragm	Hot/Cold weather tested (-40°C to 80°C) natural rubber for long service life and resistance to deterioration.
8.	Non-Pressure Chamber (NPC)	Heavy-duty 8-gauge steel NPC - embossed for added strength. Heat-fused epoxy-coated to protect against rust and corrosion.

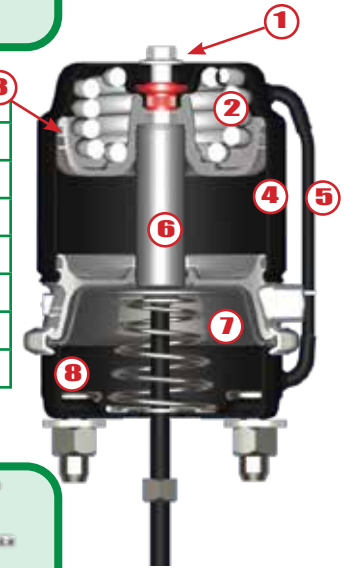

Piston brake shown

Double Diaphragm Models

- Heavy gauge NPC
- Heavy-duty reinforced diaphragms
- Stainless steel push-rod and assembly optional for air disc model
- External breather tube, seals out contaminants
- Corrosion Fighter technology is available on select sizes



Heavy Gauge NPC

LTS “Long Life” Models

- Long stroke design
- Threaded rod or welded yoke available
- Reduction in height for easier installation in compact spaces
- Center hole diaphragm allows for positive spring alignment
- Corrosion Fighter technology prevents premature spring failure
- Patented dual thread release bolt provides minimum bolt protrusion



Corrosion Fighter Guide

www.mgmbrakes.com